

ML2123 Stainless Steel Collapsible Coat Hook

Material Specifications

- #304 Stainless Steel Body
- Spring Loaded Pivot Hook with 12kg Drop-down Load Capacity
- Front Fix Mounting

Mounting

- Visible Screw Fix via front mounting points

Dimensions

- 108mmW x 108mmH x 56mmD (hook in upright position)

Installation Guidelines

- *May be subject to Australian Building Code Regulations for able bodied and/or healthcare use. Unit is to be surface mounted to appropriate substrate using appropriate screws and wall plugs for the material being affixed into.*
- *It is recommended that the unit is installed whereby it clears any other fixtures by at least 100mm and not carry loads any greater than 12kg.*

1. Locate and mark fixing position (4 x 70mm C to C or 100mm diagonal) on wall or partition and mark, ensuring the hook is level.
2. Using the pre-marked points, drill fixing holes into substrate and position appropriate wall anchors.
3. Using the appropriate screws and wall plugs, fully fasten the screws through front panel holes to secure firmly. Check the unit is level.
4. Test the hook load for operational integrity to finish installation.

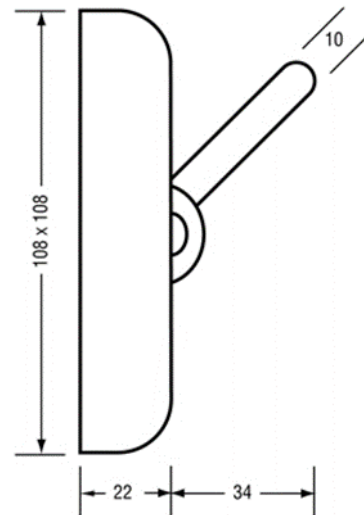

This product is AS1428.1 compliant (accessible compliant) when installed in accordance with the guidelines.

The technical recommendations contained in this document are necessarily of a general nature and should not be relied on for specific applications without first securing competent advice. Whilst Metlam Australia Pty Ltd has taken all reasonable steps to ensure the information contained herein is accurate and current, it does not warrant the accuracy or completeness of the information and does not accept liability for errors or omissions. Any Commercial product should only be installed by a competent tradesperson and serviced/maintained by knowledgeable janitorial staff or competent people. Metlam Australia accepts no responsibility for any damage to product, walls or fixtures due to incorrect installation or maintenance of any of their products.

The photographs and line drawings of the products presented above are representational only.
Metlam Australia Pty Ltd reserves the right to, and from time to time, make changes and improvements in design and dimensions.